



DV[®] MARK

Guitar at its Best!

DV "RAW DAWG" 60

EGC "RAW DAWG" 60

Owner's Manual

SAFETY INSTRUCTIONS

IMPORTANT SAFETY INSTRUCTIONS

- 1) Read these instructions;
- 2) Keep these instructions;
- 3) Heed all warnings;
- 4) Follow all instructions;
- 5) Do not use this apparatus near water;
- 6) Clean only with dry cloth;
- 7) Do not block any ventilation openings. Install in accordance with the manufacturer's instructions;
- 8) Do not install near any heat sources such as radiators, heat registers, stoves, or other apparatus (including amplifiers) that produce heat;
- 9) Do not defeat the safety purpose of the polarized or ground-type plug. A polarized plug has two blades with one wider than the other. A grounding type plug has two blades and a third grounding prong. The wide blade or the third prong are provided for your safety. If the provided plug does not fit into your outlet, consult an electrician for replacement of the obsolete outlet;
- 10) Protect the power cord from being walked on or pinched, particularly at plugs, convenience receptacles, and the point where they exit from the apparatus
- 11) Only use attachments/accessories specified by the manufacturer;
- 12) Use only with the cart, stand, tripod, bracket, or table specified by the manufacturer, or sold with the apparatus. When a cart is used, use caution when moving the cart/apparatus combination to avoid injury from the tip-over (and Fig 21 DU Tipping Cart Symbol).
- 13) Unplug this apparatus during lightning storms or when unused for long periods of time;
- 14) Refer all servicing to qualified service personnel. Servicing is required when the apparatus has been damaged in any way, such as power-supply cord or plug is damaged, liquid has been spilled or objects have fallen into the apparatus, the apparatus has been exposed to rain or moisture, does not operate normally, or has been dropped;
- 15) "WARNING: TO REDUCE THE RISK OF FIRE OR ELECTRIC SHOCK, DO NOT EXPOSE THIS APPARATUS TO RAIN OR MOISTURE AND OBJECTS FILLED WITH LIQUIDS, SUCH AS VASES, SHOULD NOT BE PLACED ON THIS APPARATUS".
- 16) TO COMPLETELY DISCONNECT THIS APPARATUS FROM THE AC MAINS, DISCONNECT THE POWER SUPPLY CORD PLUG FROM THE AC RECEPTACLE;
- 17) THE MAINS PLUG OF THE POWER SUPPLY CORD SHALL REMAIN READILY ACCESSIBLE.
- 18) In case of voltage selector make sure the switch on the rear panel is on the correct voltage before connecting it to the AC power, and the fuse is the right value for that voltage (This selector is not available on the 100V version). Please change the voltage/fuse values label located near the voltage selector matching the voltage/fuse values when you need to change the voltage of the apparatus.
- 19) "WARNING: THIS APPARATUS MUST BE SECURELY ATTACHED TO THE FLOOR OR WALL IN ACCORDANCE WITH INSTALLATION INSTRUCTION. TIPPING, SHAKING, OR ROCKING THE MACHINE MAY CAUSE INJURY OR DEATH."
- 20) "CAUTION: THESE SERVICING INSTRUCTIONS ARE FOR USE BY QUALIFIED SERVICE PERSONNEL ONLY. TO REDUCE THE RISK OF ELECTRIC SHOCK DO NOT PERFORM ANY SERVICING OTHER THAN THAT CONTAINED IN THE OPERATING INSTRUCTIONS UNLESS YOU ARE QUALIFIED TO DO SO"



MORE INFORMATION

For warranty and service information, please contact your local Markbass distributor (contact information available at www.markbass.it). For more technical information, please visit us at www.markbass.it and fill out the form on the Support page. We hope you enjoy your power amp and use it to make great music!



"The Lightning Flash with arrowhead symbol within an equilateral triangle, is intended to alert the user to the presence of uninsulated "dangerous voltage" within the product enclosure that may be of sufficient magnitude to constitute a risk of shock to persons."



"The exclamation point within an equilateral triangle is intended to alert the user to the presence of important operating and maintenance (servicing) instructions in the literature accompanying the product."



"To be used only with altitude not exceeding 2000 m"



"To be used only where the climate is not tropical"



PRECAUTIONS D'EMPLOI

- 1) Lire ces instructions;
- 2) Conserver ces instructions;
- 3) Suivre tous les conseils d'utilisations;
- 4) Suivre toutes les instructions;
- 5) Ne pas utiliser cet appareil au bord de l'eau;
- 6) Nettoyer uniquement avec un chiffon humide;
- 7) Ne pas bloquer le système de ventilation. Installer conformément aux instructions du fabricant;
- 8) Ne pas installer l'appareil près d'une source de chaleur tel qu'un radiateur, un fourneau, ou bien un autre appareil qui produit de la chaleur;
- 9) Ne pas modifier le système de sécurité de la fiche polarisée ou de la fiche pour les prises de terre. Une fiche polarisée a deux broches, l'une étant plus distante de l'autre. Une fiche pour prise de terre a deux broches et une pointe pour la masse. La broche plus distante et la pointe pour la masse ont été installées pour votre sécurité. Si la fiche fournie de rentre pas dans votre prise de courant consulter un électricien pour la substitution;
- 10) Protéger le cordon d'alimentation afin qu'il ne soit pas piétiné ou écrasé tout particulièrement au niveau des fiches, des prises de courant femelles, et des parties qui sortent de l'appareil;
- 11) Utiliser uniquement les accessoires recommandés par le fabricant;
- 12) Utiliser uniquement avec le chariot, le socle, le trépied, le support ou la table spécifiés par le fabricant ou vendu avec l'appareil. Lorsque vous utilisez un chariot, soyez prudent lorsque vous déplacez l'ensemble chariot / appareil pour éviter toute blessure du renversement (et la figure 21 DU Tipping panier Symbol).
- 13) Ne pas branché l'appareil en cas d'orage accompagné d'éclairs. Le débrancher en cas de non utilisation prolongée;
- 14) S'adresser à un service assistance agréé si l'appareil a subi des dommages, si le cordon d'alimentation ou la fiche a été endommagé, si un liquide a été renversé sur l'appareil ou bien si un objet est tombé dans l'appareil, si ce dernier a été exposé à la pluie ou à l'humidité, s'il ne fonctionne pas correctement ou s'il est tombé;
- 15) "AVERTISSANT: POUR RÉDUIRE LE RISQUE DU FEU OU DE DÉCHARGE ÉLECTRIQUE, N'EXPOSEZ PAS CET APPAREIL À LA PLUIE OU L'HUMIDITÉ ET LES OBJETS REMPLIS DE LIQUIDES; TELS QUE DES VASES, NE DEVRAIENT PAS ÊTRE PLACÉS SUR CET APPAREIL";
- 16) POUR DÉCONNECTER COMPLETEMENT L'APPAREIL DU RESEAU D'ALIMENTATION, DÉCONNECTER LE CORDON D'ALIMENTATION DE LA PRISE MURALE;
- 17) LA PRISE DU RESEAU D'ALIMENTATION DOIT DEMEURER AISEMENT ACCESSIBLE.
- 18) En cas de sélecteur de tension s'assurer que l'interrupteur sur le panneau arrière est sur la bonne tension avant de le raccorder à l'alimentation secteur et le fusible est la bonne valeur pour que la tension (Ce sélecteur n'est pas disponible sur la version 100V). S'il vous plaît changer la tension / valeurs de fusibles étiquette située près du sélecteur de tension correspondant aux valeurs / fusibles de tension lorsque vous avez besoin de changer la tension de l'appareil.
- 19) "AVERTISSEMENT: CET APPAREIL DOIT ÊTRE ASSUJETTI AU PLANCHER OU AU MUR CONFORMÉMENT AUX INSTRUCTIONS D'INSTALLATION. LE FAIT DE L'INCLINER, DE LE BALANÇER OU DE L'AGITER PEUT CAUSER DES BLESSURES OU LA MORT."
- 20) "ATTENTION: CES INSTRUCTIONS D'ENTRETIEN SONT DESTINÉES PAR PERSONNEL QUALIFIÉ SEULEMENT . POUR RÉDUIRE LE RISQUE DE CHOC ÉLECTRIQUE NE PAS EFFECTUER TOUT ENTRETIEN AUTRE QUE CELLES CONTENUES DANS TEH MODE D'EMPLOI SAUF SI VOUS ÊTES QUALIFIÉ POUR LE FAIRE"

MARK VISION

A Word from Marco De Virgiliis

Thank you for choosing the **DV MICRO** head!

In the years I made Markbass a world leader brand in the bass amps segment, using technology to better serve bass players needs: **great tone, reliability, versatility/flexibility** and **light weight**. all those elements made their lives way easier!

Now it's guitar players turn... with the new **DV MICRO** heads I created an exciting new chapter in guitar amplification history, being the **first** to introduce such a kind of guitar products design that marked a **new standard** for **ultra-portable** and **great sounding** amps, offering to guitar players **plenty of power** and **serious headroom**.

This amp also features a **Dual Voltage Switch** 120V/240V (not available on the 100V version manufactured for Japan) to use the amp in countries with different voltages, without having to carry an external converter!

At DV Mark, we invested a lot of resources in R&D to develop a **proprietary power amp**, designed to respect and glorify the tone of your instrument.

So **enjoy my amps**, and I invite you to contact us any time with your comments and questions, at **info@dvmark.it**.

Thanks again, and good music!



Marco De Virgiliis



OVERVIEW

DV "RAW DAWG" 60 - EGC "RAW DAWG" 60

Eric Gales is one of the most interesting artists on the modern blues scene not only because of his unique skills and phrasing on guitar, but also due to a pretty personal way to sculpt his tone.

This **Eric's signature amp** is a single channel **tube driven** channel head. That's the perfect scenario Eric needs to free his mind and paint this perfect canvas with his pedals colors, and the **60 watt MPT** power amp makes this lightweight head the perfect choice for small and medium venues where you need to feel the punch and dynamic of an amp working on its ideal power range.

FRONT PANEL - DV “RAW DAWG” 60 - EGC “RAW DAWG” 60

INPUT Connect your guitar to this input using a standard ¼” shielded instrument cable. It’s also designed to perfectly interface with all the effects most used by guitarists.

AUX Use this input to plug in an iPod, CD or MP3 player using a mini plug 1/8”. This signal mixes in evenly with your instrument input.

LEVEL This knob sets the input level, turn it up gradually until you reach your desired volume.

BASS This knob controls the amount of low frequencies in your sound.

MID The Middle control regulates the midrange frequencies and it is an important part of your tone shaping.

HIGH The High knob controls the amount of high frequencies in your sound.

REVERB Level control for the onboard reverb. This amp features a last generation of digital reverb, it’s sweet-sounding, warm and natural.

PHONES For quiet practicing plug headphones into this mini plug 1/8” input. You can practice anywhere and anytime you like.

ON/OFF SWITCH This switch delivers AC power to the amp.



REAR PANEL - DV "RAW DAWG" 60 - EGC "RAW DAWG" 60

AC POWER SOCKET Make sure the unit is grounded; all three terminals of the AC power plug must be connected to avoid any injury to the user or damage to the unit.

VOLTAGE SELECTOR The DV MICRO heads feature a 120V/240V Voltage Selector to use the amp in countries with different voltages, so make sure the switch on the rear panel is on the correct voltage before connecting it to the AC power, and the fuse is the right value for that voltage (not available on the 100V version manufactured for Japan).

Please change the voltage/fuse values label located near the voltage selector matching the voltage/fuse values when you need to change the voltage of the unit.

FSW 1/4" MONO jack for connecting a SINGLE footswitch to turn ON/OFF the reverb

SEND/RETURN The send/return can be used for connecting with outboard effect processors or pedals. Simply connect the Send out to your processor's input, and connect the output of your processor to the Return in.

SPEAKER OUT The two speaker outputs provided for speaker cabinet connections are wired in parallel and total minimum impedance load for the amp is 4 ohms, so you can connect one or two 8 ohms speakers or only one 4 ohms speaker.

Use speaker cable (not instrument cable).



TECHNICAL SPECS - DV "RAW DAWG" 60 - EGC "RAW DAWG" 60

Channels: One (clean)
Controls: Level
EQ Controls: Bass - Mid - High
Speaker Outputs: Two ¼" Jacks mono out 8 ohm
Power Output: 60W @ 4ohm / 50W @ 8ohm
Other Features: Footswitch input for reverb on/off
AUX IN
Headphones OUT
XLR Line OUT with GND Lift
Dual Voltage selector 120V/240V
(not available on the 100V version manufactured for Japan)

Dimensions: 200 x 64 x 221 mm / 7.87" x 2.51" x 8.7" (DV"RAW DAWG" 60)
435 x 425 x 305 mm / 17.12" x 16.73" x 12" (EGC"RAW DAWG" 60)

Weight: 1,9 kg / 4.19 lbs (DV"RAW DAWG" 60)
11 Kg / 24.25 lbs (EGC"RAW DAWG" 60)

Power Requirement: 120V; 230V; 240V - 50/60Hz
100V - 50/60Hz (version manufactured for Japan)

Speaker size: One 1x12" DV Mark Custom (EGC"RAW DAWG" 60)

FUSES: T 2A 250V for 100V/120V setting;
T 1A 250V for 230V/240V setting

BLOCK DIAGRAM

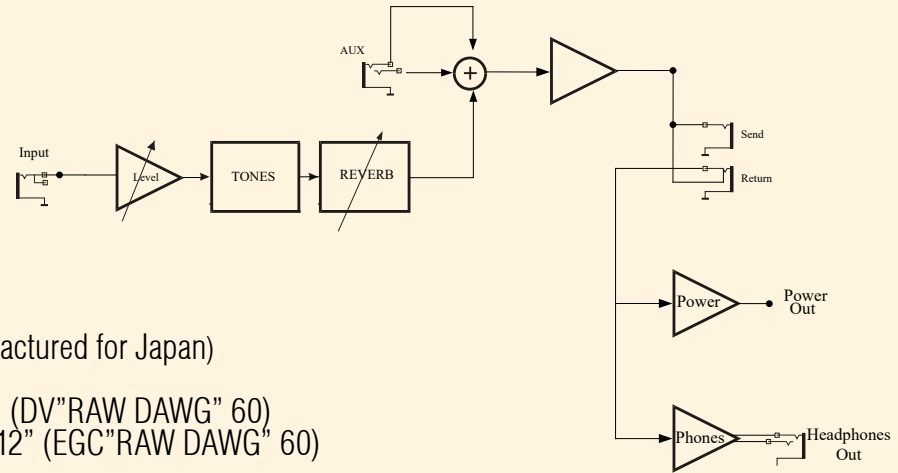

Product specifications are subject to change without notice

DV MARK

Guitar *at its Best!*



Parsek srl - Italy - 66020 San Giovanni Teatino CH - Via Po, 52

Tel: +39 0854407764 / 0854465705 - Fax: +39 0854407764 / 0854407399 - www.dvmark.it - info@dvmark.it